

### Features

- Unique 3-way design for locking quarter turn actuators in multiple positions for applications which require modulated flow
- Solenoids can be pulsed independently to bleed air into or out of actuator for fine positioning
- Direct acting on/off construction
- NAMUR mount construction reduces complex piping arrangements
- 10X32, 10X24, M5 hardware supplied

### Construction

Valve Parts in Contact with Fluids		
Body	Brass	303 Stainless Steel
Seals and Discs	NBR	
Core Tube	305 Stainless Steel	
Core and Plugnut	430F Stainless Steel	
Core Springs	302 Stainless Steel	
Shading Coil	Copper	Silver
Disc-Holder	CA	
Core Guide	CA	

### Electrical

Standard Coil and Class of Insulation	Watt Rating and Power Consumption				Spare Coil Part Number			
	DC Watts	AC			General Purpose		Explosionproof	
		Watts	VA Holding	VA Inrush	AC	DC	AC	DC
F	11.6	10.1	25	50	238610	238710	238614	238714

Standard Voltages: 24, 120, 240, 480 volts AC, (or 100, 200 volts AC, 50 Hz)  
6, 12, 24, 120, 240 volts DC. Must be specified when ordering.  
Other voltages available when required.

### Solenoid Enclosures

**Standard:** Watertight, Types 1, 2, 3, 3S, 4, and 4X.

**Optional:** Explosionproof and Watertight, Types 3, 3S, 4, 4X, 6, 6P, 7, and 9.

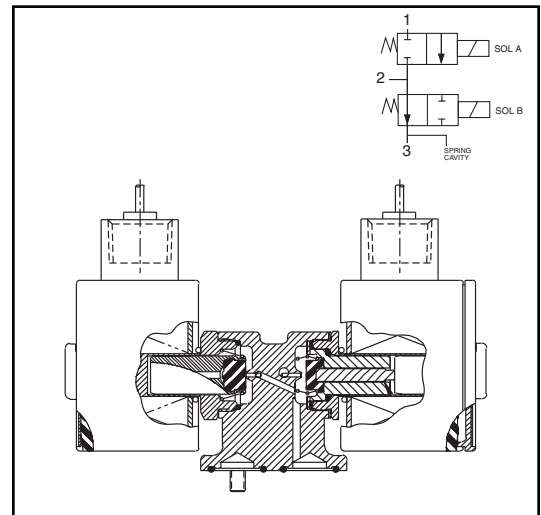

VALVE  
AUTOMATION

### Options

Explosionproof solenoids are available.

Prefix EF - Brass

Prefix EV - Stainless Steel

All other RedHat Solenoid options are available.

*Optional elastomer contact ASCO.*

### Nominal Ambient Temp. Ranges

AC: 32°F to 125°F (0°C to 52°C)

DC: 32°F to 104°F (0°C to 40°C)

*Refer to Engineering Section for details.*

### Approvals

UL recognized component. CSA certified.

Meets applicable CE directives.

*Refer to Engineering Section for details.*

**Specifications (English units)**

Pipe Size (ins.)	Orifice Size (ins.)	Cv Flow Factor	Operating Pressure Differential (psi)		Max. Fluid Temp. °F		Brass Body	Stainless Steel Body	Watt Rating/ Class of Coil Insulation	
			Max. AC	Max. DC	AC	DC			AC	DC
1/4	1/16	.09	150	125	140	120	8320G706	8320G716	10.1/F	11.6/F
1/4	3/32	.12	120	100	140	120	8320G707	8320G717	10.1/F	11.6/F
1/4	1/8	.25	100	65	140	120	8320G708	8320G718	10.1/F	11.6/F

**Specifications (Metric units)**

Pipe Size (ins.)	Orifice Size (mm)	Kv Flow Factor (m3/h)	Operating Pressure Differential (bar)		Max. Fluid Temp. °C		Brass Body	Stainless Steel Body	Watt Rating/ Class of Coil Insulation	
			Max. AC	Max. DC	AC	DC			AC	DC
1/4	1.6	.07	10	9	60	50	8320G706	8320G716	10.1/F	11.6/F
1/4	2.4	.10	8	6.9	60	50	8320G707	8320G717	10.1/F	11.6/F
1/4	3.2	.16	6.9	4	60	50	8320G708	8320G718	10.1/F	11.6/F

**Dimensions inches (mm)**

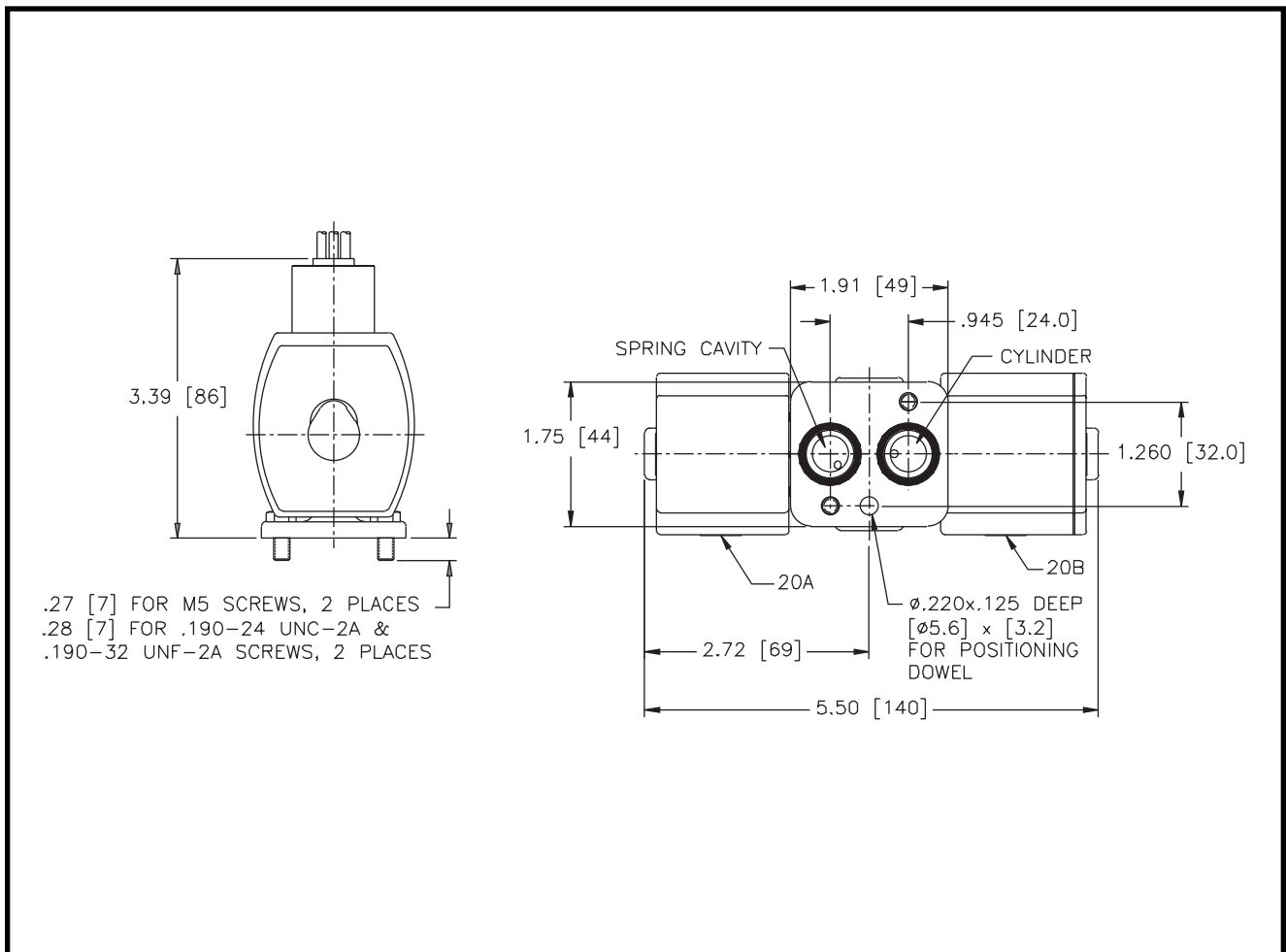

VALVE  
AUTOMATION